



UNIC-ST-PRO-1500 AIR BLAST SPRAYER

SPARE PARTS



SPRAYER N°:

MANUF. YEAR:

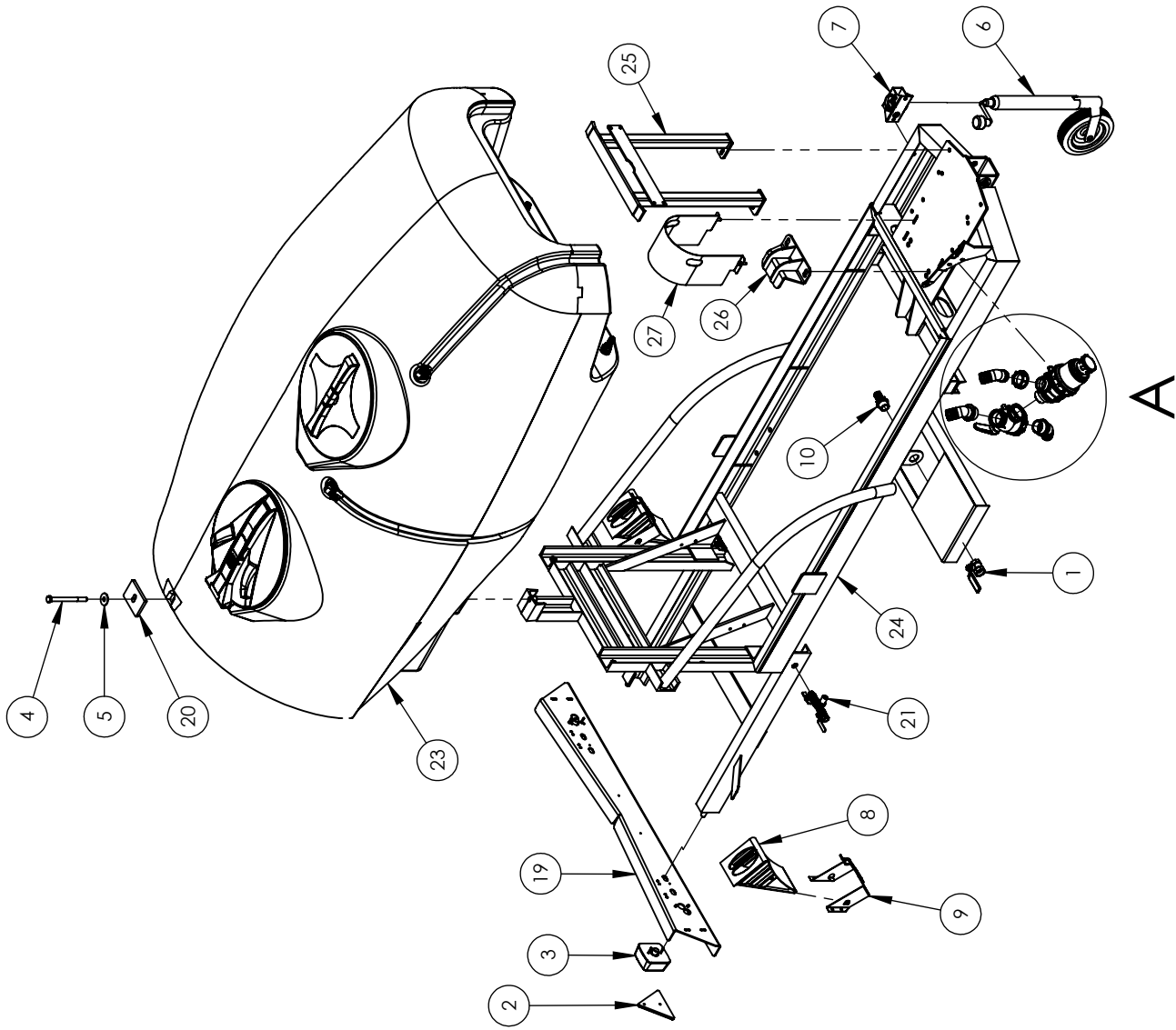

Suavizar aristas
Cotas sin tolerancia según ISO2768-1 en grado m (medio)

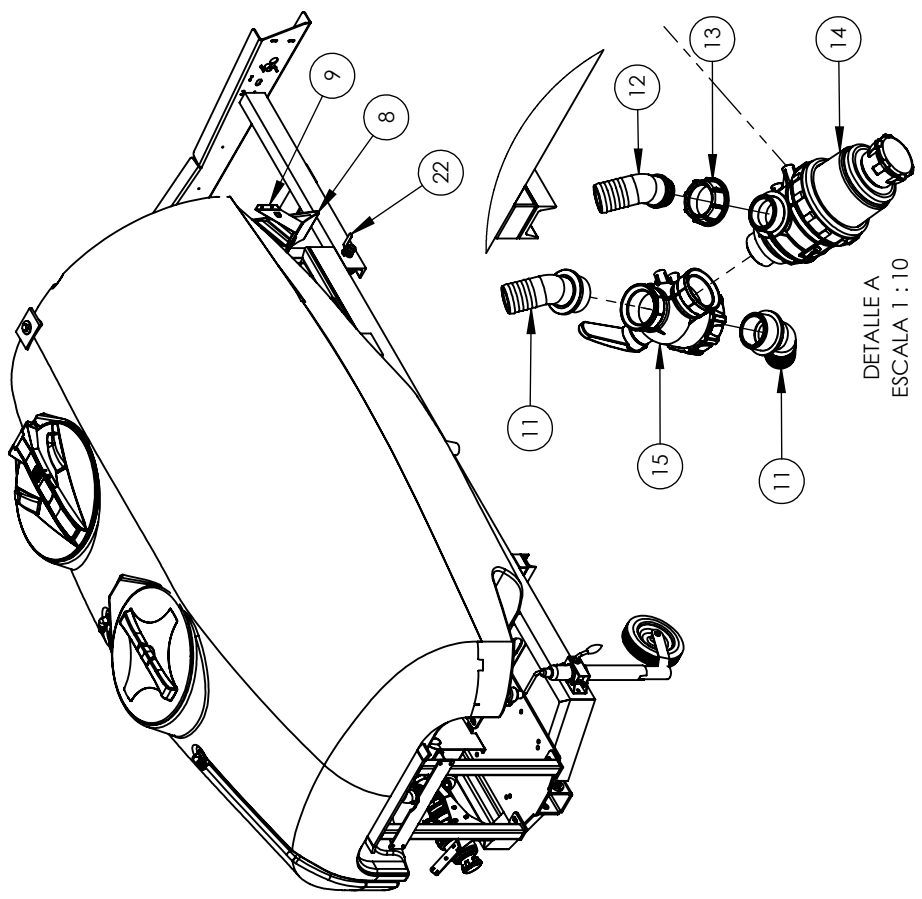

DETALLE A
ESCALA 1 : 10

Denominación: EQUIPO BASE ARRASTRADO ST 1500		Nº hoja: 1/2
Material: 1500 Lts		Peso: 1935,32kg
Dibujado: 06/11/2018	M. Amorós	
Modificado:		
Tipo acabado: -----		
Interviene en:		
<p align="center">ATEMIZADORES ARRASTRADOS</p> <p align="center">Nº Plano T010015000</p> <p align="center">Versión 00</p> <p align="center">Proceso Montaje</p>		<p align="center">ESCALA</p> <p align="center">1:25</p>
<p align="center">TEYME Tecnología Agrícola, s.l.</p> <p align="center">Pol. Ind. SAU 3, C/ Girona - 25131 TORRESERONA (Lleida) - SPAIN Telf. 973 750 033 - Fax. 973 751 581 www.teyme.es - e-mail: comercial@teyme.es</p>		



Este plano es propiedad de TEYME Tecnología Agrícola, S.L. Prohibida su reproducción y cesión a terceros.

UNIC-ST-1500 FRAME

Nº	CODE	DESCRIPTION
1	0170020005	FF 1" BALL VALVE
2	0190011002	RED TRIANGLE RETROREFLECTOR
3	0190011006	LEFT PILOT LIGHT INCAND LIGHTS KIT (100x100)
4	0500201416	DIN931 8.8 M14x160 SCREW
5	0550150014	DIN-9021 M14 WIDE FLAT WASHER
6	0860020001	ECHONOMICAL M/SUP R-48-RDAG-200 X 50 JACKWHEEL
7	0860020002	BR-48 -ST CLAMP FOR JACKWHEEL
8	1000900022	TYPE 360 CHOCK
9	1000900023	TYPE 360 CHOCK HOLDER
10	A001032425	M 1" Ø25 P.P.STRAIGHT FITTING
11	A00114640	P.P. 1 1/2" Ø40 45º CURVED MALE THREAD FITTING
12	A00117640	D.40 X GIR. 1 1/2 45º CURVED FITTING
13	A002002060	1"1/2 NUT F/FITTING
14	A003142462	314 SUCTION FILTER W/ M 1 1/2" R24mm RED 32M VALVE
15	A0045521116	F-1 1/2 3 WAYS BALL VALVE
19	2000400520	BUMPER FOR FRAME 264/396/528 GAL
20	2100700033	TANK REAR HOLDER PLATE Zn
21	2400140469	THREE GUNS TAP KIT
22	2400140469	THREE GUNS TAP KIT
23	T010100006	396 GAL MAIN TANK + CLEAN WATER TANK
24	2400045809	WELDED 396 GAL PAINTED FRAME
25	2400045860	FRAME CONTROL HOLDER PAINTED SET
26	2400045861	HOLDER CLAMP KIT - Zn
27	2400048571	PTO PUMP PROTECTION WIDE PLATE KIT

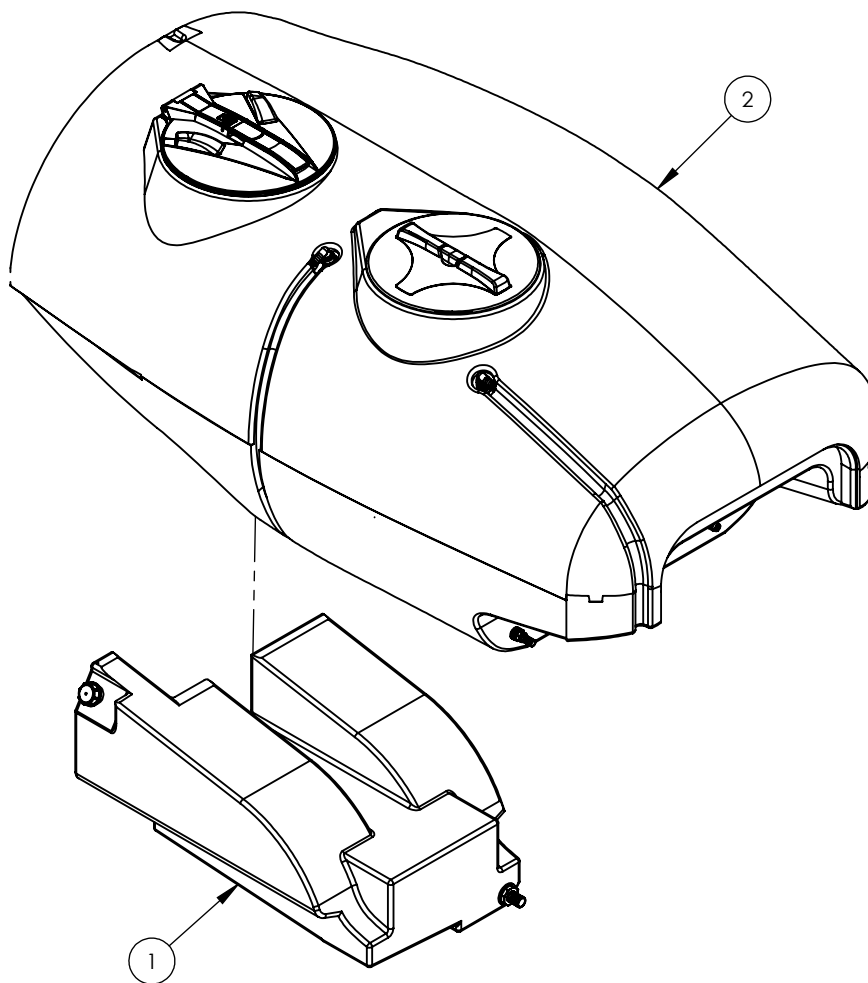
N	N_pieza	Denominación	Cant.	Proceso	Peso
1	2400088093	SBCJTO.SUBDEPOSITO EQUIPO SUSPENDIDO 1500	1	Mecanizado	160.10
2	240028D025	SCJTO. DEP. TEYME 1500 GRIS 2E+1B M.E. T.A. V.S.	1	Montaje	1577.21



Denominación: CJTO DEPOSITO + SUBDEPOSITO 1500 - 2018			Nº hoja: 1/1	
Material: 1500 Lts			Peso: 1737.32kg	
Dibujado	08/10/2018	M. Amorós	Tipo acabado: ----	
Modificado			Interviene en: ATOMIZADORES ARRASTRADOS	
 Pol. Ind. SAU 3, C/ Girona - 25131 TORRESERONA (Leida) - SPAIN Telf. 973 750 033 - Fax. 973 751 581 www.teyme.es - e-mail: comercial@teyme.es			Nº Plano T010100006	
			Proceso Montaje	ESCALA 1:20
			Versión 00	

Suavizar aristas
Cotas sin tolerancia según ISO2768-1 en grado m (medio)

396 GAL TANK KIT

Nº	CODE	DESCRIPTION
1	2400088093	AUXILIARY RINSING TANK
2	240028D025	TEYME 396 GAL GREY 2E+1B M.E. T.A. V.S. TANK

N_pieza	Denominación	Cant.	Proceso	Peso
1	RACOR CURVO P.P. H 3/4-Ø19	3	Compra Std	0.02
2	TUERCA PP 1/2"	2	Compra Std	0.01
3	TUERCA PP 2"	1	Compra Std	0.04
4	UNION P.P. M-M 2" 51x24	1	Compra Std	0.12
5	AGITADOR HID. EUROMIX STANDARD Ø2,5 mm.	2	Compra Std	1.91
6	VALVULA ANTIRRETORNO LATON H-H 1/2"	1	Compra Std	0.10
7	JUNTA TORICA D.24x3,5	3	Compra Std	0.00
8	JUNTA TORICA P/R 2 40X2,5	2	Compra Std	0.00
9	JUNTA PLANA SILICONA 1/2	2	Compra Std	0.01
10	JUNTA PLANA NEGRA 2"	1	Compra Std	0.01
11	RACOR RECTO P.P. 1/2" H Ø19	1	Compra Std	0.01
12	CODO Ø50 MACHO T7	1	Compra Std	0.21
13	TUERCA P.P. P/RACOR 1"	1	Compra Std	0.01
14	RACOR DESAGUE 3/4" 43 mm	3	Compra Std	0.02
15	RACOR DESAGUE G1" 50mm	1	Compra Std	0.02
16	UNION PASAPARED P.P. M-M 1/2" 38x18	2	Compra Std	0.02
17	FILTRO FORMA DE SACO 18 MESH Ø400 380x275mm LARGO	1	Compra Std	1.39
18	JUNTA BASE PARA TAPA Ø454 ARAG	1	Compra Std	0.37
19	TAPA ROSCADA SMOOTH LINE2 C/RESP LABER GHIBLI Ø455	1	Compra Std	0.98
20	COPERCHIO RIBALT. D.455 S.P.+BLOCCO	1	Compra Std	0.32
21	DEPOSITO-ARRAS.POLILETENO 1500 L - GRIS 7038 95Kg	1	Compra c/plano	1568.98
22	MEZCLADOR DE FONDO"BOT MIX"BOQ.2,5	1	Montaje	0.64

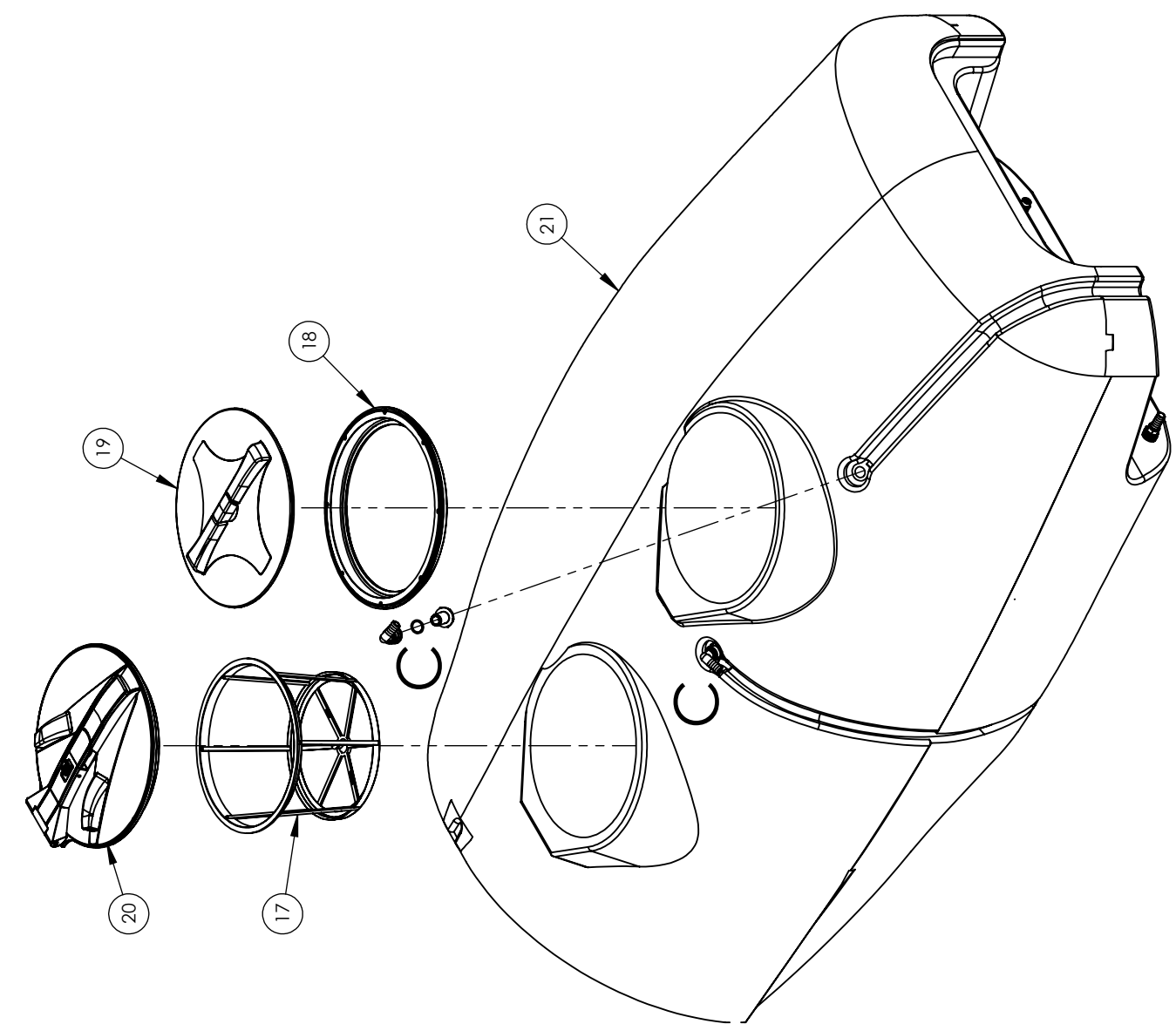
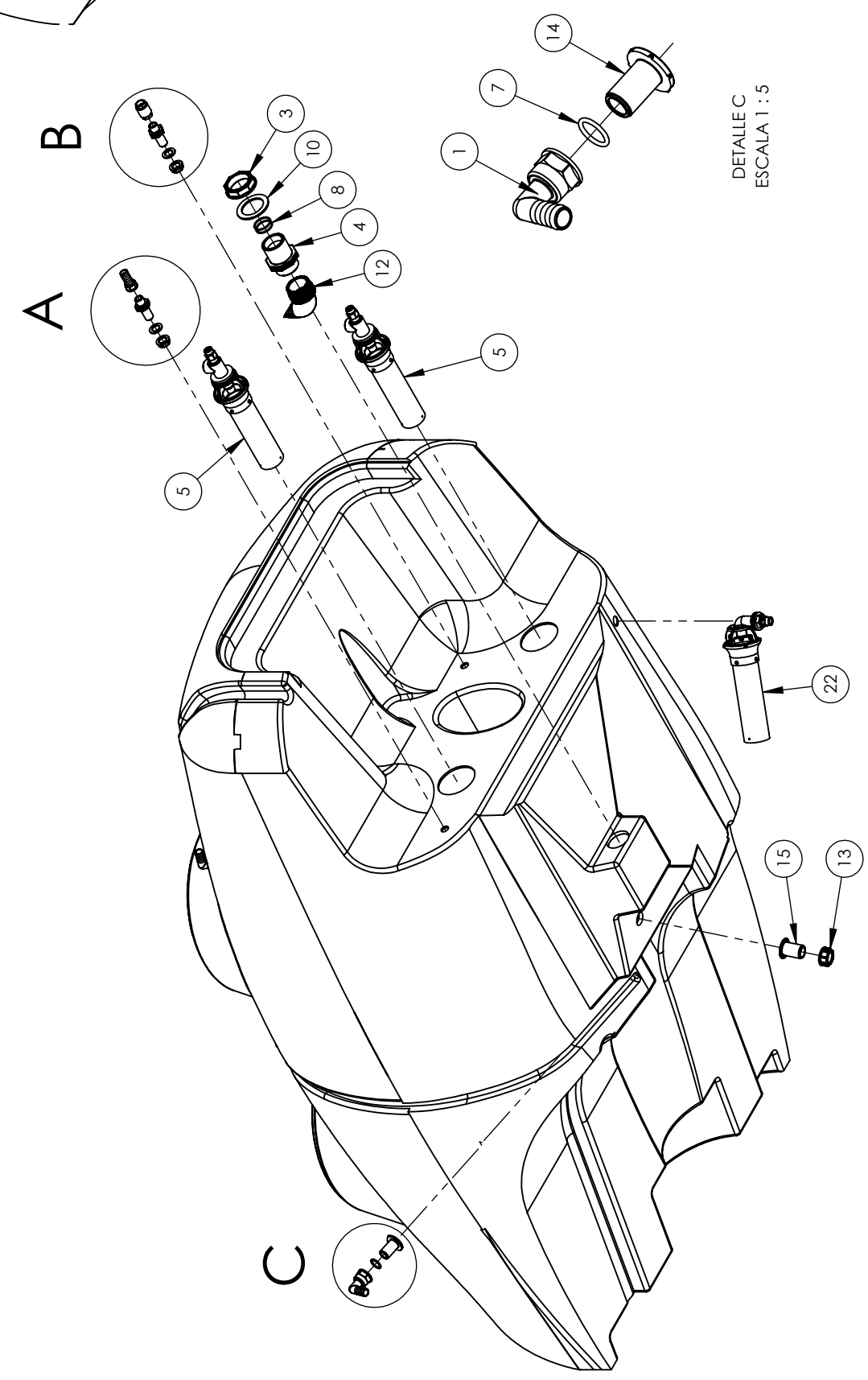
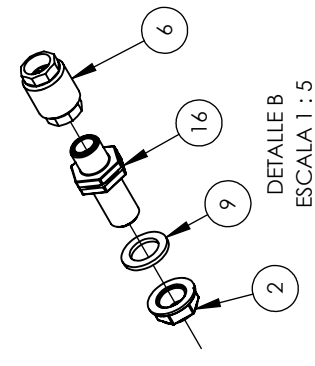
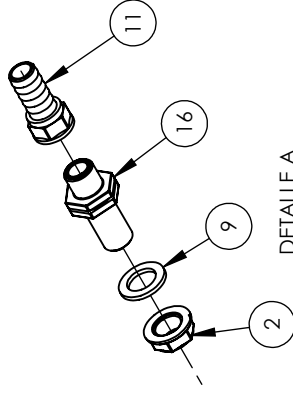

Denominación: SCJTO. DEP. TEYME 1500 GRIS 2E+1B M.E. T.A. V.S. N° hoja: 1/1
Material: 1500Lts Peso: 1577.21kg
Dibujado: 08/10/2018 M. Amorós Tipo acabado:
Modificado: Interviene en:
TEYME ATOMIZADORES ARRASTRADOS ESCALA
Tecnología Agrícola, s.l. N° Plano 240028D025 ESCALA
(Lleida) - SPAIN Versión 1:15
Pol. Ind. SAU 3, C/ Girón - 25131 TORRESERONA Proceso Montaje Versión 00
Tel. 973 750 033 - Fax 973 751 681
www.teyme.es - e-mail: comercial@teyme.es

Suavizar aristas
Cotas sin tolerancia según ISO2768-1 en grado m (medio)

396 GAL TANK

Nº	CODE	DESCRIPTION
1	0020020001	P.P. F 3/4-Ø19 CURVED FITTING
2	0020120001	PP 1/2" NUT
3	0020120006	PP 2" NUT
4	0020200010	P.P. M-M 2" 51x24 UNION
5	0090020002	EUROMIX STANDARD Ø2,5 mm. HYDRAULIC STIRRER
6	0140060012	H-H 1/2" BRASS ANTIRETURN VALVE
7	0790010014	D.24x3,5 GASKET
8	0790010060	P/R 2 40X2,5 GASKET
9	0790060010	1/2 " FLAT GASKET
10	0790060040	2" BLACK FLAT GASKET
11	A00100219	P.P. 1/2" F Ø19 STRAIGHT FITTING
12	A001191750	Ø50 MALE T7 ELBOW
13	A002002040	P.P. NUT FOR 1" FITTING
14	A00220030	3/4" 43 mm DRAIN HOSE FITTING
15	A00220040	G1" 50mm DRAIN HOSE FITTING
16	A002502021	P.P. M-M 1/2" 38x18 BULKHEAD UNION
17	A00300130	18 MESH Ø400 380x275mm TANK FILLING FILTER
18	A00350460020	BASE JOINT FOR Ø454 ARAG LID
19	A003522261	SMOOTH LINE2 VENTING GHIBLI Ø455 THREADED LID
20	A00356061	D.455 S.P.COLLAPSIBLE LID
21	1100011510	TRAILED POLYETHYLENE 396 GAL GREY 7038 TANK
22	0090010007	"BOT MIX"BOQ.2,5 BOTTOM STIRRER

N	N_pieza	Denominación	Cant.	Proceso	Peso
1	0020130004	TAPON HEMBRA P.P. 1 1/2"	1	Compra Std	0.03
2	0790060020	JUNTA PLANA NBR	1	Compra Std	0.00
3	1100010200	SUBDEPOSITO-ARRAS.POLIETILENO 200 L - AZUL 5012	1	Compra Std	159.68
4	A001032630	RACOR RECTO P.P. M 1 1/2" Ø30	1	Compra Std	0.36
5	A00230560	UNION SIMPLE P.P. 1 1/2" 38x46	1	Compra Std	0.03

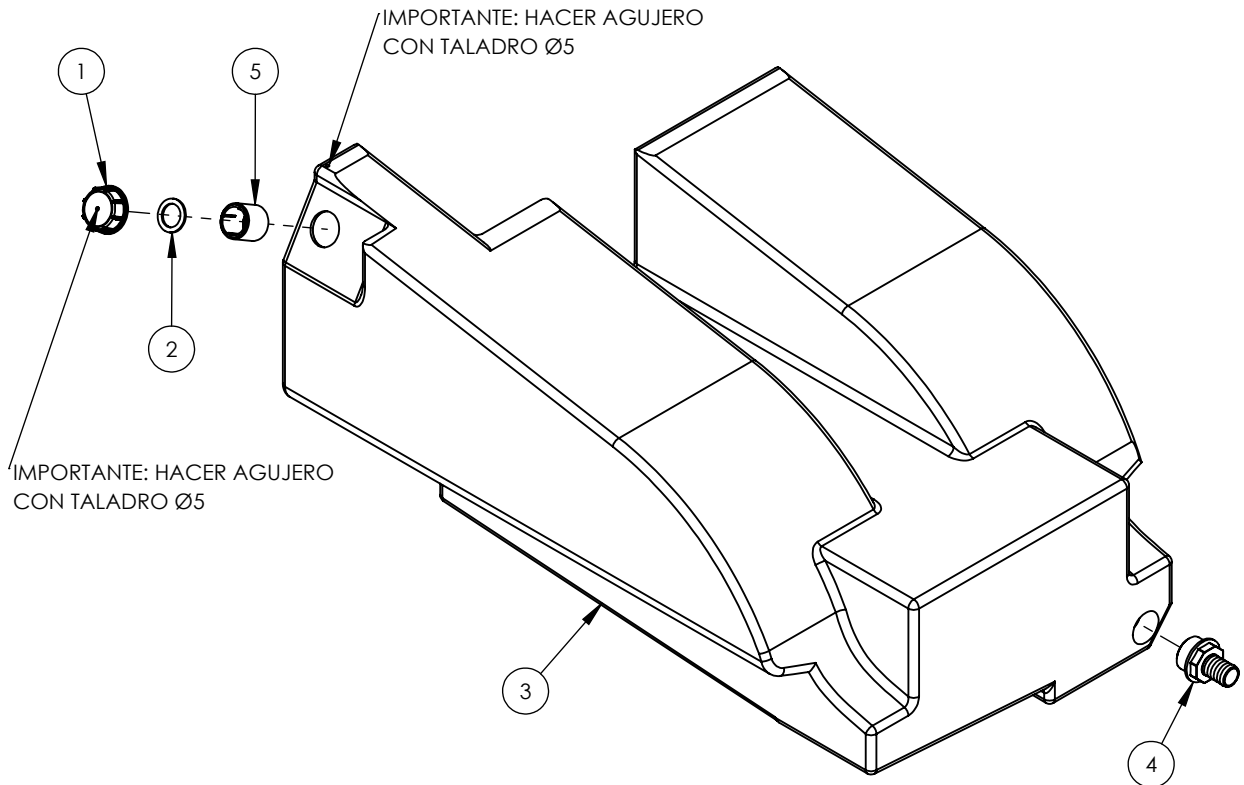

Denominación: SBCJTO.SUBDEPOSITO EQUIPO SUSPENDIDO 1500			Nº hoja: 1/1	
Material: 200Lts			Peso: 160.10kg	
Dibujado	03/10/2018	M. Amorós	Tipo acabado: ----	
Modificado			Interviene en: ATOMIZADORES ARRASTRADOS	
 Pol. Ind. SAU 3, C/ Girona - 25131 TORRESERONA (Leida) - SPAIN Telf. 973 750 033 - Fax. 973 751 581 www.teyme.es - e-mail: comercial@teyme.es			Nº Plano	ESCALA
			2400088093	1:10
Proceso			Versión	
Mecanizado			00	

Suavizar aristas
Cotas sin tolerancia según ISO2768-1 en grado m (medio)

396 GAL CLEAN WATER TANK

Nº	CODE	DESCRIPTION
1	0020130004	P.P. 1 1/2" FEMALE BLANKING CAP
2	0790060020	NBR FLAT GASKET
3	1100010200	POLYETHYLENE CLEAN WATER 52 GAL TANK- 5012 BLUE
4	A001032630	P.P. M 1 1/2" Ø30 STRAIGHT FITTING
5	A00230560	P.P. 1 1/2" 38x46 SIMPLE UNION

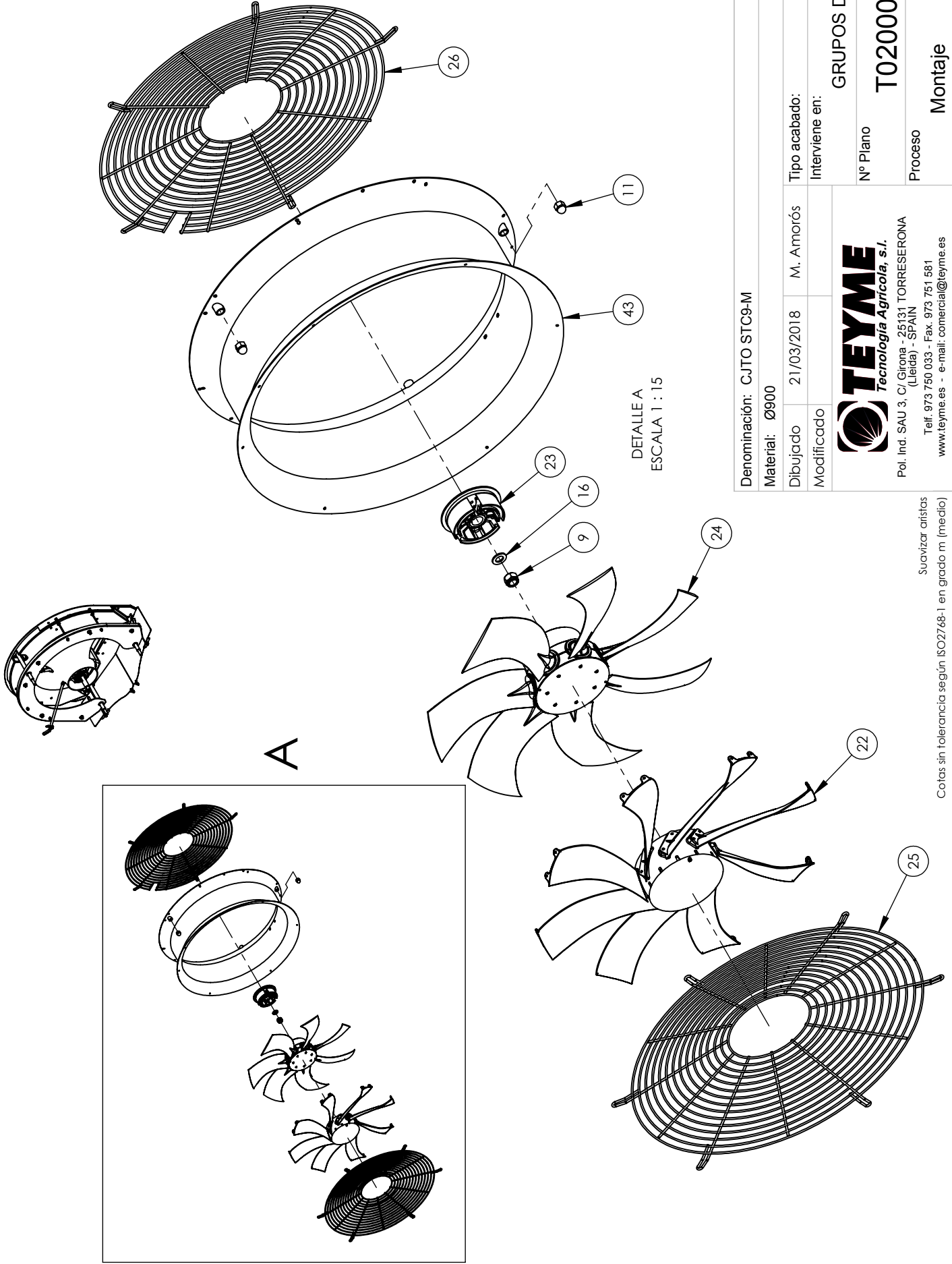

DETALLE A
ESCALA 1 : 15

Denominación: CJTO STC9-M		Nº hoja: 1/3
Material: Ø900		Peso: 172.72kg
Dibujado	21/03/2018	M. Amorós
Modificado		
Tipo acabado:		Interviene en:
GRUPOS DE AIRE		Nº Plano
T020000012		Proceso
Versión		00
Montaje		ESCALA
		1:40
 TEYME Tecnología Agrícola, s.l. Pol. Ind. SAU 3, C/ Girona - 25131 TORRESEERONA (Lleida) - SPAIN Telf. 973 750 033 - Fax. 973 751 581 www.teyme.es - e-mail: comercial@teyme.es		Este plano es propiedad de TEYME Tecnología Agrícola, S.L. Prohibida su reproducción y cesión a terceros.

Cotar sin tolerancia según ISO2768-1 en grado m (medio)
 Suavizar aristas

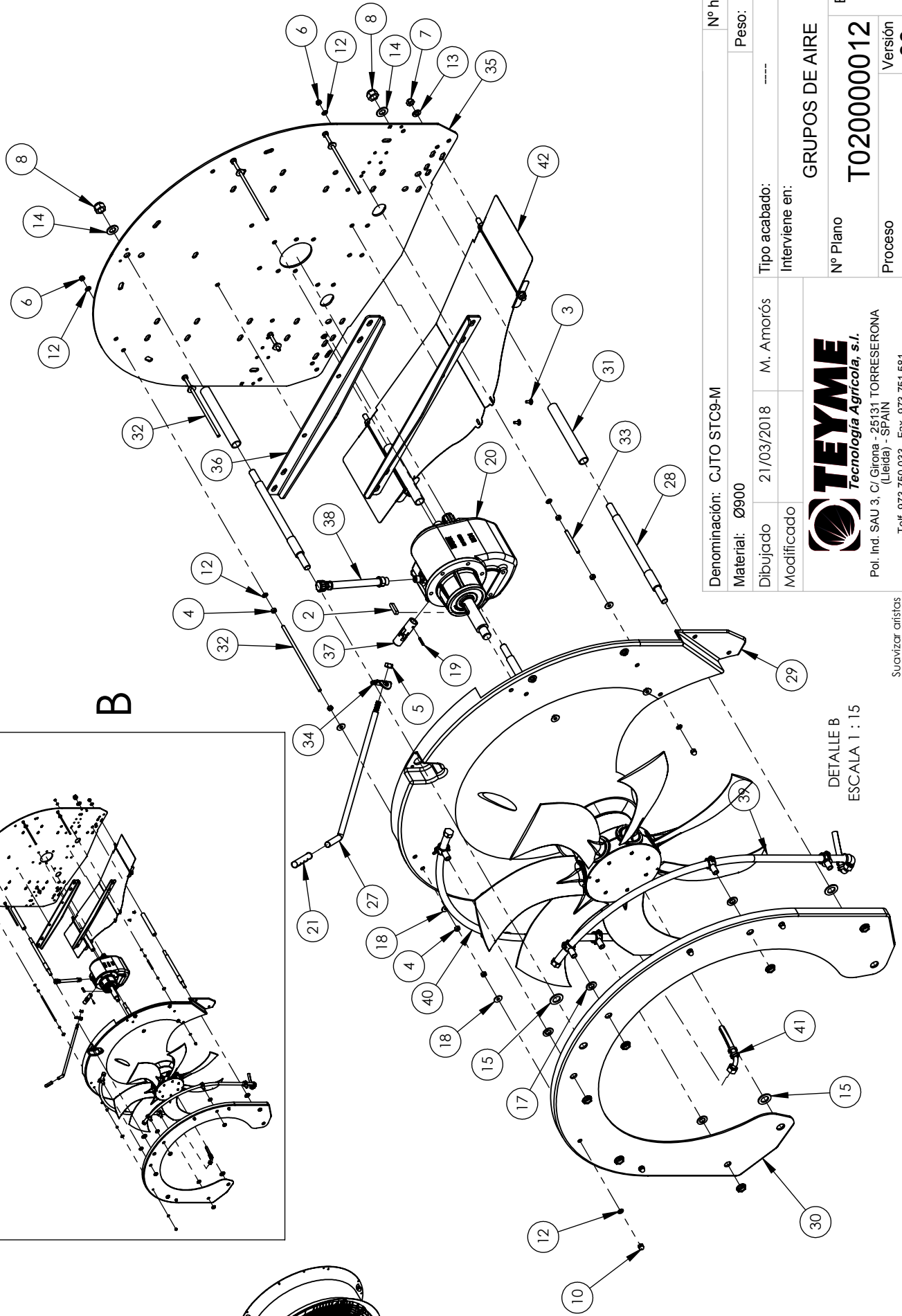
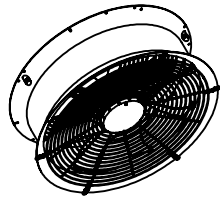
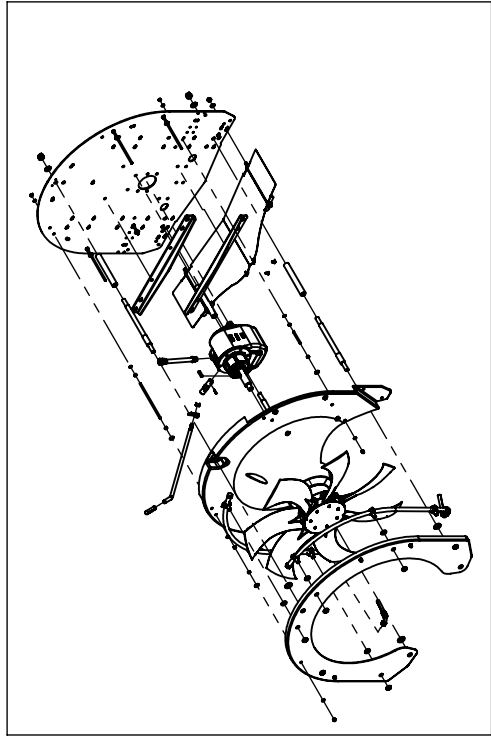

DETALLE B
ESCALA 1 : 15

Denominación: CJTO STC9-M		Nº hoja: 2/3
Material: Ø900		Peso: 172.72kg
Dibujado	21/03/2018	M. Amorós
Modificado		
Tipo acabado:		Interviene en:
		GRUPOS DE AIRE
Nº Plano		T020000012
Proceso		Montaje
Versión		00
 TEYME Tecnología Agrícola, s.l. Pol. Ind. SAU 3, C/ Gitona - 25131 TORRESERONA (Lleida) - SPAIN Telf. 973 750 033 - Fax. 973 751 581 www.teyme.es - e-mail: comercial@teyme.es		ESCALA 1:40

Suavizar aristas
Cotas sin tolerancia según ISO2768-1 en grado m (medio)

ST9C FAN

Nº	CODE	DESCRIPTION
1	0010140002	1/2" BRASS NUT
2	0270011008	DIN-6885 A 10x8x40 KEY
3	0502500616	DIN-603 INOX M6x16 SCREW
4	0520100800	DIN-934 8.8 Zn M8 NUT
5	0520101200	HEX. DIN-934 M12 ZN NUT
6	0521100800	D-985 AUTOBL. Zn M8 NUT
7	0521101200	D-985 AUTOBL. Zn M12 NUT
8	0521101800	D-985 AUTOBL. Zn M18 NUT
9	0521102200	HEX. DIN-985 M24 ZN NUT
10	0522100800	D-1587 NICKEL. M8 NUT
11	0522110018	DIN 1587 M18 BRASS NUT
12	0550100008	D-125 Zn Ø8 FLAT WASHER
13	0550100012	D-125 Zn Ø12 FLAT WASHER
14	0550100018	D-125 Zn Ø18 FLAT WASHER
15	0550100022	DIN-125 M22 FLAT WASHER
16	0550100024	DIN-125 M24 FLAT WASHER
17	0550120016	D-125 INOX D.16 WASHER
18	0550150008	D-9021 Zn Ø8 WASHER
19	0650010626	DIN-1481 D.5x30 LOCKING PIN
20	1160020121	DV3600 2 VEL 1:3,5 - 1:4,2 M LIFTMOUNTED GEAR BOX
21	2331000002	SHIFT LEVER KNOB
22	2400040600	34" PVS DEFLECTOR
23	2400040602	MEC BIG ZAMAK CLUTCH SET
24	2400040606	34" FULL PLASTIC FAN 7 ARS WITHOUT ADAPTER
25	1140020023	GTE-10 FAN SUCTION GRID
26	1140020025	Ø34" i-STAR & STAR EXIT GRID PAINTED
27	2250160028	GTU8 -GEAR BOX SHIFT LEVER Zn
28	2250250084	GTC9E SHAFT- Zn
29	2331000277	TURBO GTU8/E - 9E MEC CONE
30	2331000293	GTC9/E RAL 7001 POLYETHYLENE CHANNEL
31	2250280054	Zn GTC9 MID CHANNEL DIVIDER SLEEVE
32	3000200800	DIN-975 INOX A2 M8 THREADED ROD
33	3000200800	DIN-975 INOX A2 M8 THREADED ROD
34	2000400497	SHIFT LEVER HOLDER
35	2000500338	PRINCIPAL PLATE
36	T020300021	GTC9 ST MODEL 22 JETS - PAINTED REINFORCEMENT
37	1202000105	Zn PTO SHAFTGEAR SHIFT CROSSHEAD
38	2400045610	OIL FILLING HOSE KIT
39	2400045868	GTC9 RIGHT ARCH KIT
40	2400045869	GTC9 LEFT ARCH KIT
41	2400308016	FEEDING HOSE KIT
42	T020000013	GTC9 DEFLECTORS KIT
43	2400048533	Ø34"x14"UNIC INOX BLOWER HOUSING KIT

N	N_pieza	Denominación	Cantf.	Proceso	Peso
1	0130010040	MANOMETRO INOX. 1/4 0-40 VERT RES. 2bar.	1	Compra Std	0.09
2	B00966	MANDO BY MATIC 50 C/MANOMETRO	1	Compra Std	1.20
3	2400040312	CJTO. SOPORTE MANDO MANUAL COMET - Zn	1	Soldadura	0.38

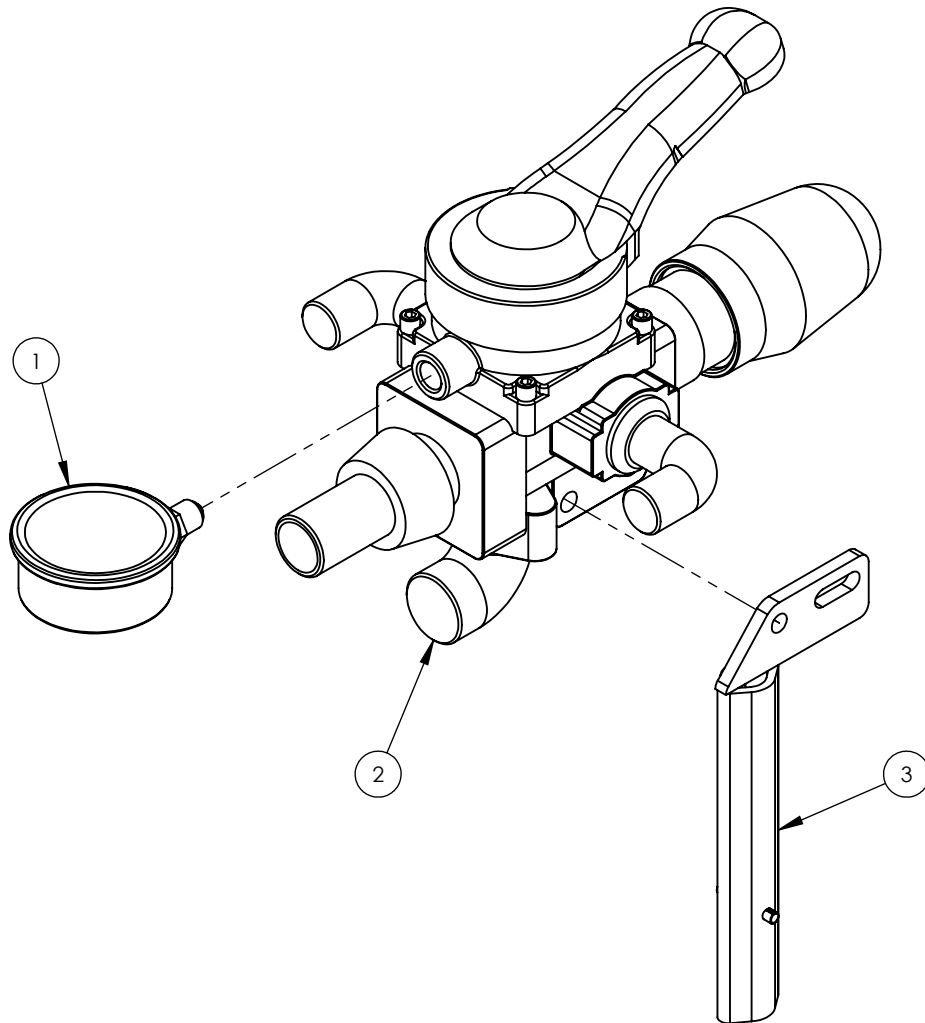

Denominación: CJTO. MANDO DISTANCIA COMET				Nº hoja: 1/1		
Material:				Peso: 1.67kg		
Dibujado	27/11/2018	M. Amorós	Tipo acabado: ----			
Modificado			Interviene en:			
 Pol. Ind. SAU 3, C/ Girona - 25131 TORRESERONA (Leida) - SPAIN Telf. 973 750 033 - Fax. 973 751 581 www.teyme.es - e-mail: comercial@teyme.es			EQUIPOS POLIETILENO			
			Nº Plano	2400041640	ESCALA	
			Proceso	Montaje	Versión	00

Suavizar aristas
Cotas sin tolerancia según ISO2768-1 en grado m (medio)

MECHANICAL CONTROL

Nº	CODE	DESCRIPTION
1	0130010040	PSI PRESSURE GAUGE
2	B00966	MECHANICAL CONTROL
3	2400040312	MECHANICAL CONTROL HOLDER

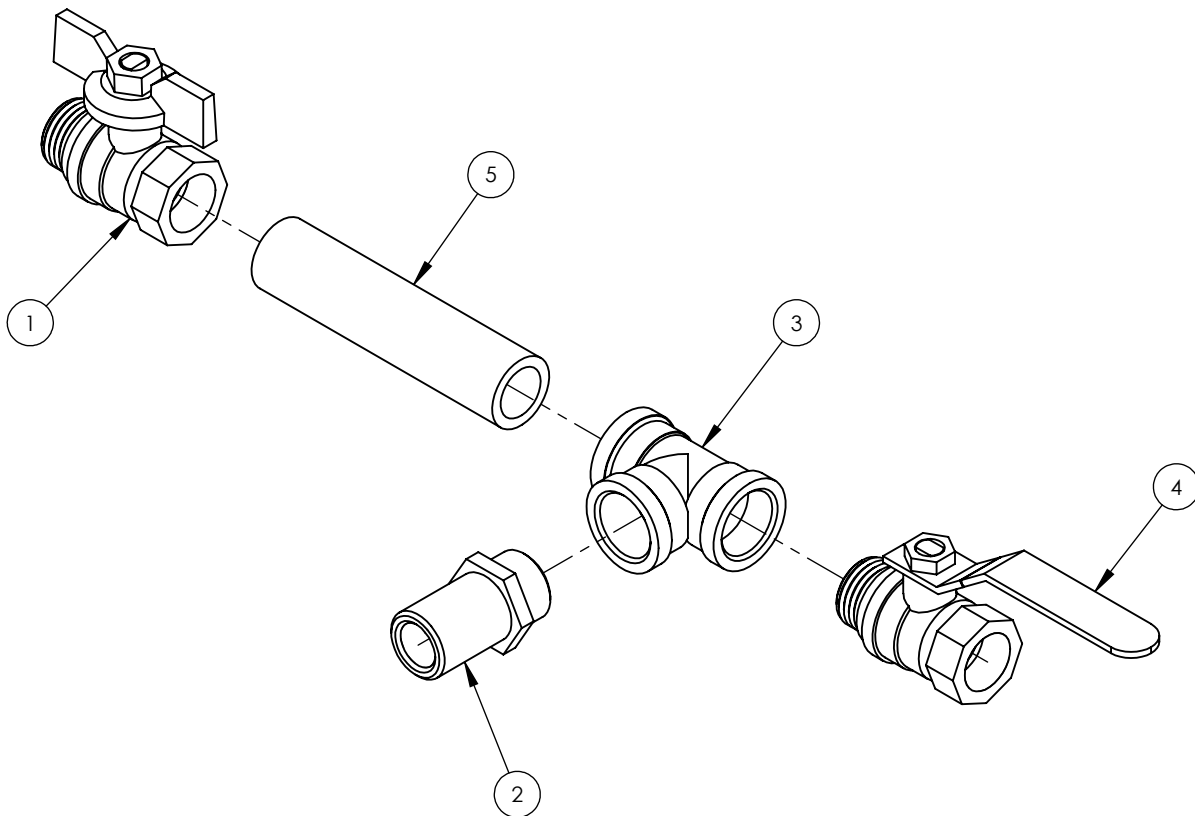

N	N_pieza	Denominación	T A DRETA	Proceso	Peso
1	0170010002	VALV.ESFERA M-H 1/2 T3000-MAR	1	Compra Std	0.16
2	0010030003	UNION LATON M-M 1/2" LARGA	1	Compra Std	0.06
3	0010120001	RACOR LATON T H-H-H 1/2	1	Compra Std	0.09
4	0170010001	VALV.ESFERA M-H 1/2 T3000-PALANCA	1	Compra Std	0.13
5	T010515001	MECHA 1/2" PASAMUROS CHASIS 1516	1	Mecanizado	0.13

Denominación: SCJTO GRIFO PISTOLA 2/3/4000

Nº hoja: 1/1

Material:

Peso: 0.62kg

Dibujado	06/09/2018	M. Amorós	Tipo acabado:	----
Modificado	03/12/2018	M. Amorós	Interviene en:	ATOMIZADORES ARRASTRADOS
 Pol. Ind. SAU 3, C/ Girona - 25131 TORRESERONA (Leida) - SPAIN Telf. 973 750 033 - Fax. 973 751 581 www.teyme.es - e-mail: comercial@teyme.es			Nº Plano	2400140469
			Proceso	Montaje
				ESCALA 1:2
				⊕ ⊖

Suavizar aristas

Cotas sin tolerancia según ISO2768-1 en grado m (medio)

THREE WAYS TAP KIT

Nº	CODE	DESCRIPTION
1	0170010002	M-H 1/2" T3000 BALL VALVE
2	0010030003	M-M 1/2" LONG BRASS UNION
3	0010120001	H-H-H 1/2" T HOSE FITTING
4	0170010001	M-H 1/2" T3000 LEVER VALVE
5	T010515001	1/2" FRAME BULKHEAD UNION



Pol. Ind. SAU III · C/ Girona, 3
25131 TORRE-SERONA (Lleida) · SPAIN

T: (+34) 973 75 00 33

F: (+34) 973 75 15 81

comercial@teyme.es



www.teyme.es